

## SC NOVAPROIECT SRL

Registrul comertului nr J33/1563/2007  
Strada Rulmentului nr.5 Bl 52 Sc A ap.4, Jud. Suceava, Romania  
Cod unic de inregistrare 22569792  
Telefon 0740238021  
e- mail : [movaproiect1@gmail.com](mailto:movaproiect1@gmail.com)

# PROIECT NR. 1/2020

"MODERNIZARE DRUM VICINAL DIN DC 46B

LA HOTAR CU HORODNIC DE SUS IN COMUNA HORODNIC DE JOS, JUDETUL SUCEAVA"

-PIESE DESENATE-

Beneficiar : COMUNA HORODNIC DE JOS, JUDETUL SUCEAVA  
Amplasament : com .HORODNIC DE JOS, județul SUCEAVA  
Proiectant : SC. NOVAPROIECT SRL

2020

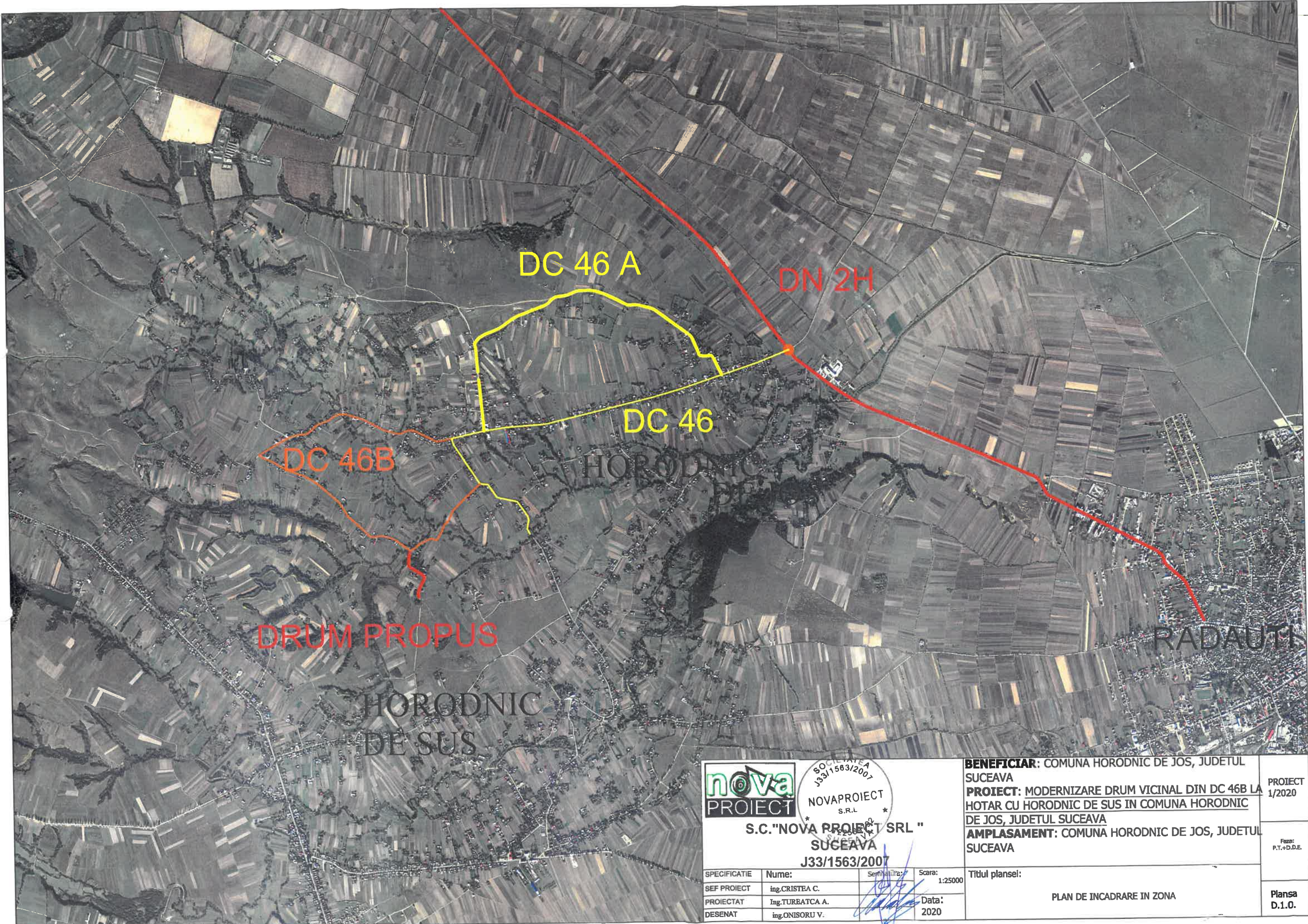

S.C. "NOVA PROJECT SRL"  
SUCEAVA  
J33/1563/2007

SPECIFICATIE	Nume:	Semnatura:	Scara:
SEF PROIECT	ing. CRISTEA C.	<i>[Signature]</i>	1:25000
PROIECTAT	ing. TUREATCA A.		Data:
DESEMAT	ing. ONISORU V.		2020

**BENEFICIAR:** COMUNA HORODNIC DE JOS, JUDETUL SUCEAVA  
**PROIECT:** MODERNIZARE DRUM VICINAL DIN DC 46B LA HOTAR CU HORODNIC DE SUS IN COMUNA HORODNIC DE JOS, JUDETUL SUCEAVA  
**AMPLASAMENT:** COMUNA HORODNIC DE JOS, JUDETUL SUCEAVA

Titlul plansei:  
 PLAN DE INCADRARE IN ZONA

PROIECT 1/2020  
 Faza: P.T.+D.D.E.  
 Plansa D.1.0.

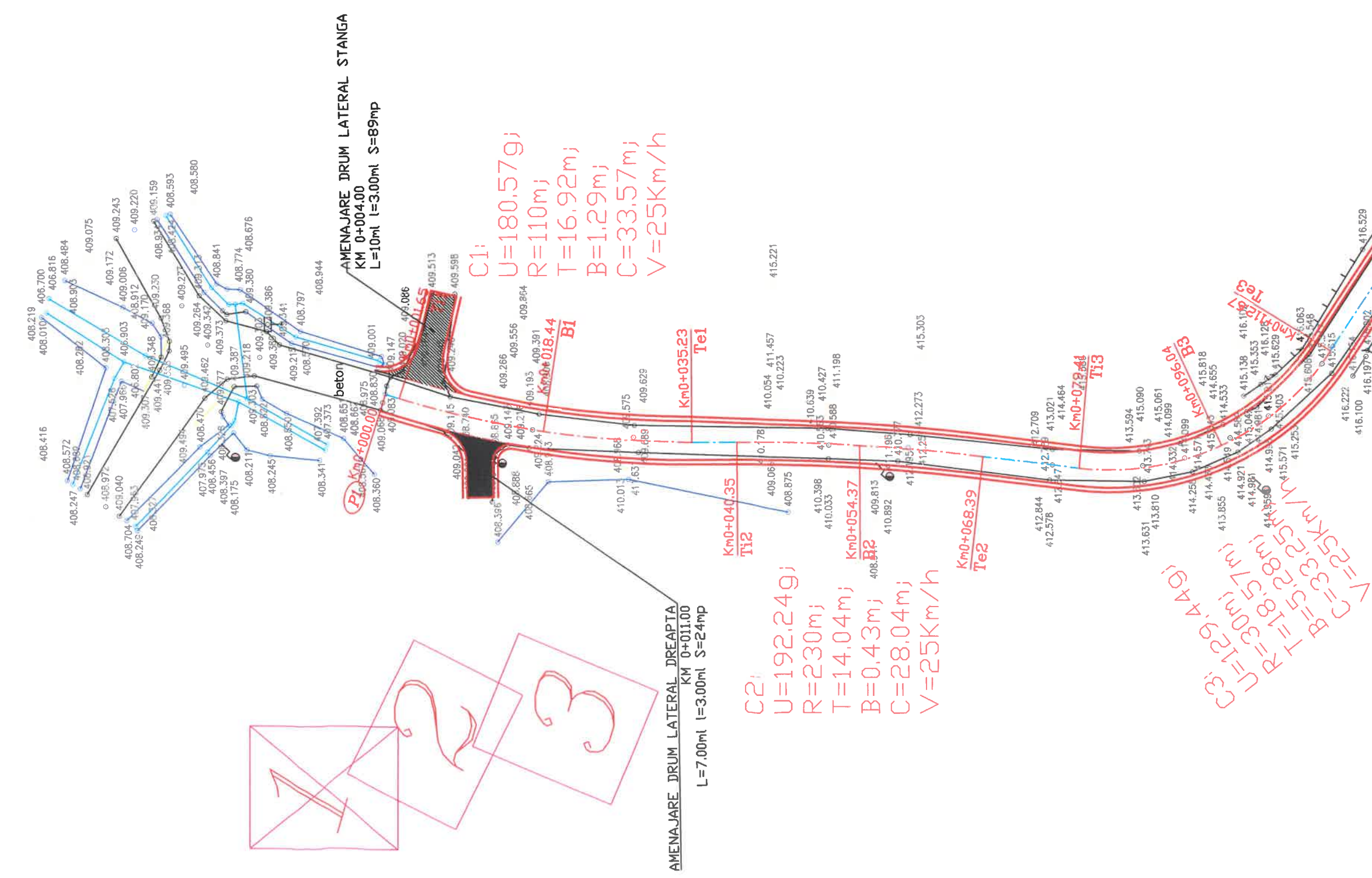

123

**HARTA CHEIE:**



**PROIECTAT:**

**NOVA PROIECT**  
 SOCIETATE NOVA  
 PROIECT S.R.L.  
 NOVA PROIECT S.R.L.  
 J33/1563/2007/BU/RO 22569792  
 SUCEAVA, STR. RULMENTULUI  
 NR.5 BLD. SC. A 07.4  
 Telefon: 07498338021  
 EMAIL: novaproiect@gmail.com

**VERIFICATOR:**

NUME:

SEMNTURA	
CERINTA	
REFERAT NR./DATA	

**BENEFICIAR:**

COMUNA HORODNIC DE JOS  
 JUDEȚUL SUCEAVA

**DENUMIRE PROIECT:**

„MODERNIZARE DRUM  
 VICINAL DIN DC 46B LA HOTAR  
 CU HORODNIC DE SUS IN  
 COMUNA HORODNIC DE JOS,  
 JUDEȚUL SUCEAVA,

**FAZA:**

PROIECT TEHNIC  
 +  
 DETALII DE EXECUTIE

SEF PROIECT	SEMNTURA
Ing. Claudiu Dumitru CRISTEA	
PROIECTAT	SEMNTURA
Ing. Alexandru-Catalin TUREATCA	
DESENAT	SEMNTURA
Ing. Vlad ONISDRU	

**DENUMIRE PLANSA:**

PLAN DE SITUATIE  
 DRUM VICINAL

PLANSA NR.:	D 2.1.
SCARA:	1:500
PROIECT NR.:	1/2020
DATA:	2020

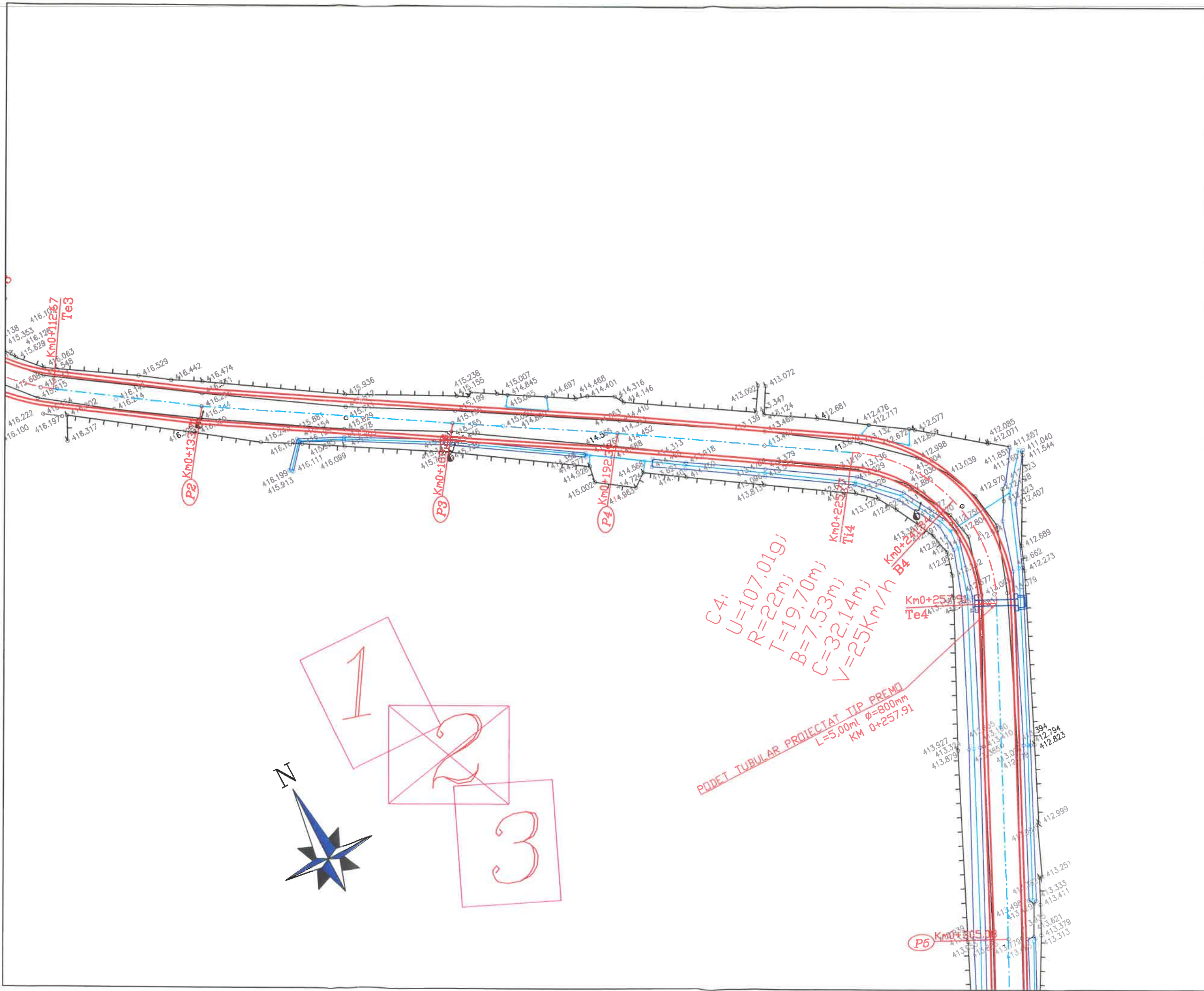

HARTA CHEIE:



PROIECTAT:

**NOVA PROJECT** SOCIETATEA SA  
 PROIECT S.R.L.  
 NOVA PROJECT S.R.L.  
 J33/1563/2007, CUI RO 22569792  
 SUCEAVA, STR. RULMENTULUI NR.5 Bl.52 Sc. CA, ap. 46  
 Telefon: 0740238025  
 EMAIL: novaproject@gmail.com

VERIFICATOR:

NUME:	
SEMNTURA	
CERINTA	
REFERAT NR./DATA	

BENEFICIAR:

COMUNA HORODNIC DE JOS  
 JUDEȚUL SUCEAVA

DENUMIRE PROIECT:

„MODERNIZARE DRUM VICINAL DIN DC 46B LA HOTAR CU HORODNIC DE SUS ÎN COMUNA HORODNIC DE JOS, JUDEȚUL SUCEAVA,

FAZA:

PROIECT TEHNIC  
 +  
 DETALII DE EXECUTIE

SEF PROIECT	SEMNTURA
Ing. Claudiu Dumitru CRISTEA	
PROIECTAT	SEMNTURA
Ing. Alexandru-Catalin TUREATCA	
DESENAT	SEMNTURA
Ing. Vlad DNISORU	

DENUMIRE PLANSA:

PLAN DE SITUATIE  
 DRUM VICINAL

PLANSA NR.:	D 2.2.
SCARA:	1:500
PROIECT NR.:	1/2020
DATA:	2020

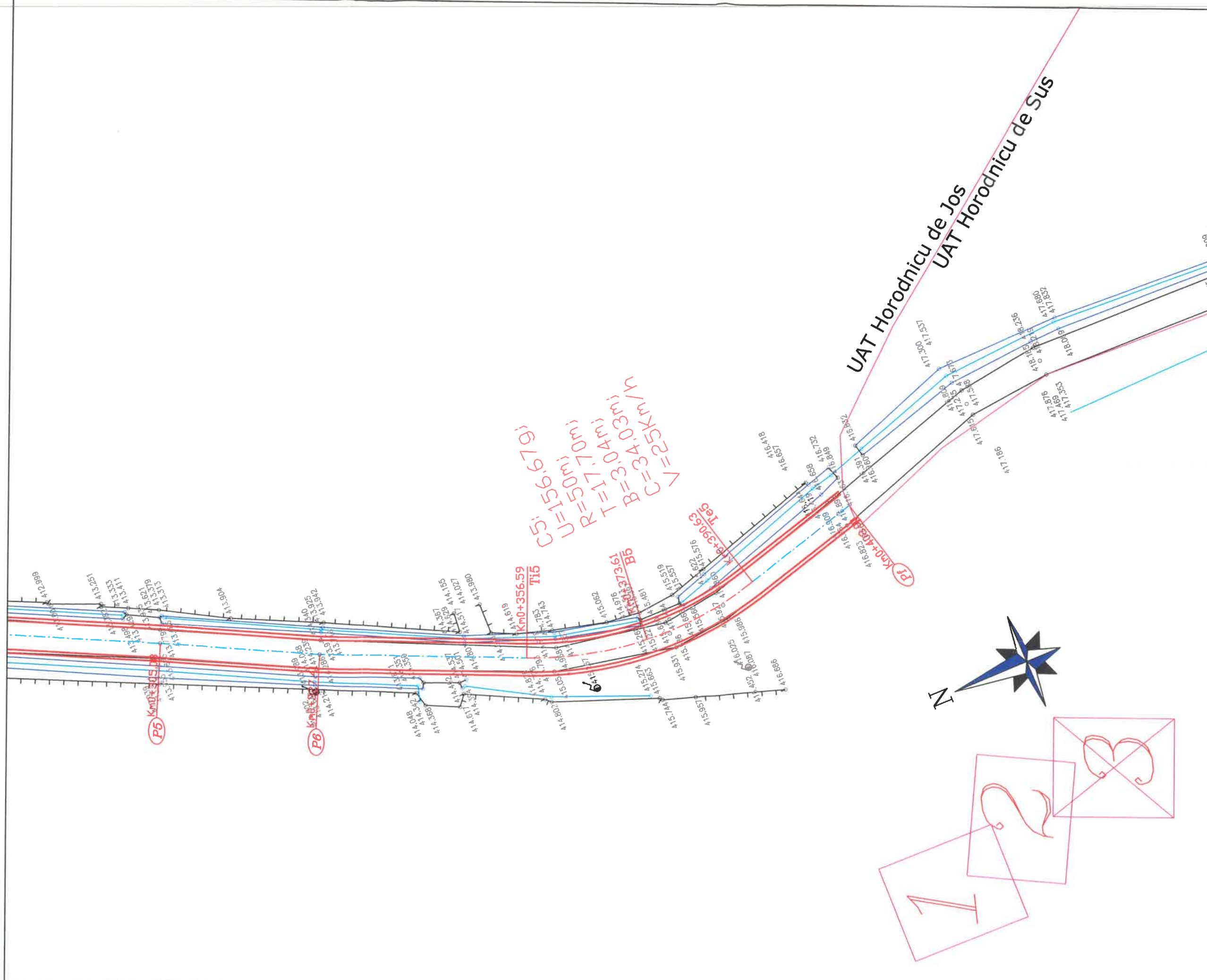

HARTA CHEIE:



PROIECTAT:

**NOVA** S.C. NOVA  
 PROIECT S.R.L.  
 J33/1563/2007, CUI RO 22569792  
 SUCEAVA, STR. ROMANILOR  
 NR.5 Bl.52 Sc. Ap.4  
 Telefon: 0740238021  
 EMAIL: novaproject@ceva.ro

VERIFICATOR:

NUME: \_\_\_\_\_  
 SEMNATURA \_\_\_\_\_  
 CERINTA \_\_\_\_\_  
 REFERAT NR./DATA \_\_\_\_\_

BENEFICIAR:

COMUNA HORODNIC DE JOS  
 JUDEȚUL SUCEAVA

DENUMIRE PROIECT:

„MODERNIZARE DRUM  
 VICINAL DIN DC 46B LA HOTAR  
 CU HORODNIC DE SUS ÎN  
 COMUNA HORODNIC DE JOS,  
 JUDEȚUL SUCEAVA,

FAZA:

PROIECT TEHNIC  
 +  
 DETALII DE EXECUȚIE

SEF PROIECT	SEMNATURA
Ing. Claudiu Dumitru CRISTEA	
PROIECTAT	SEMNATURA
Ing. Alexandru-Catalin TUREATCA	
DESENAT	SEMNATURA
Ing. Vlad DNISDRU	

DENUMIRE PLANSA:

PLAN DE SITUAȚIE  
 DRUM VICINAL

PLANSA NR.: D 2.3.  
 SCARA: 1:500  
 PROIECT NR.: 1/2020  
 DATA: 2020

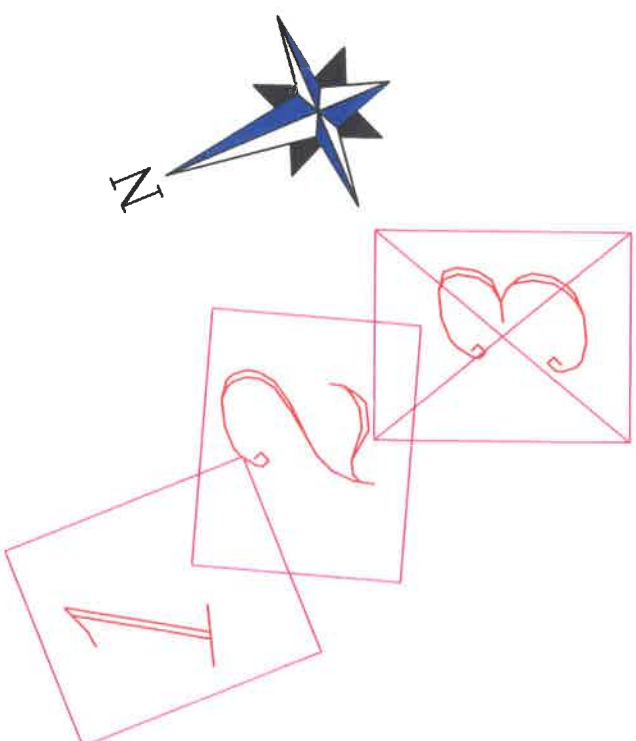

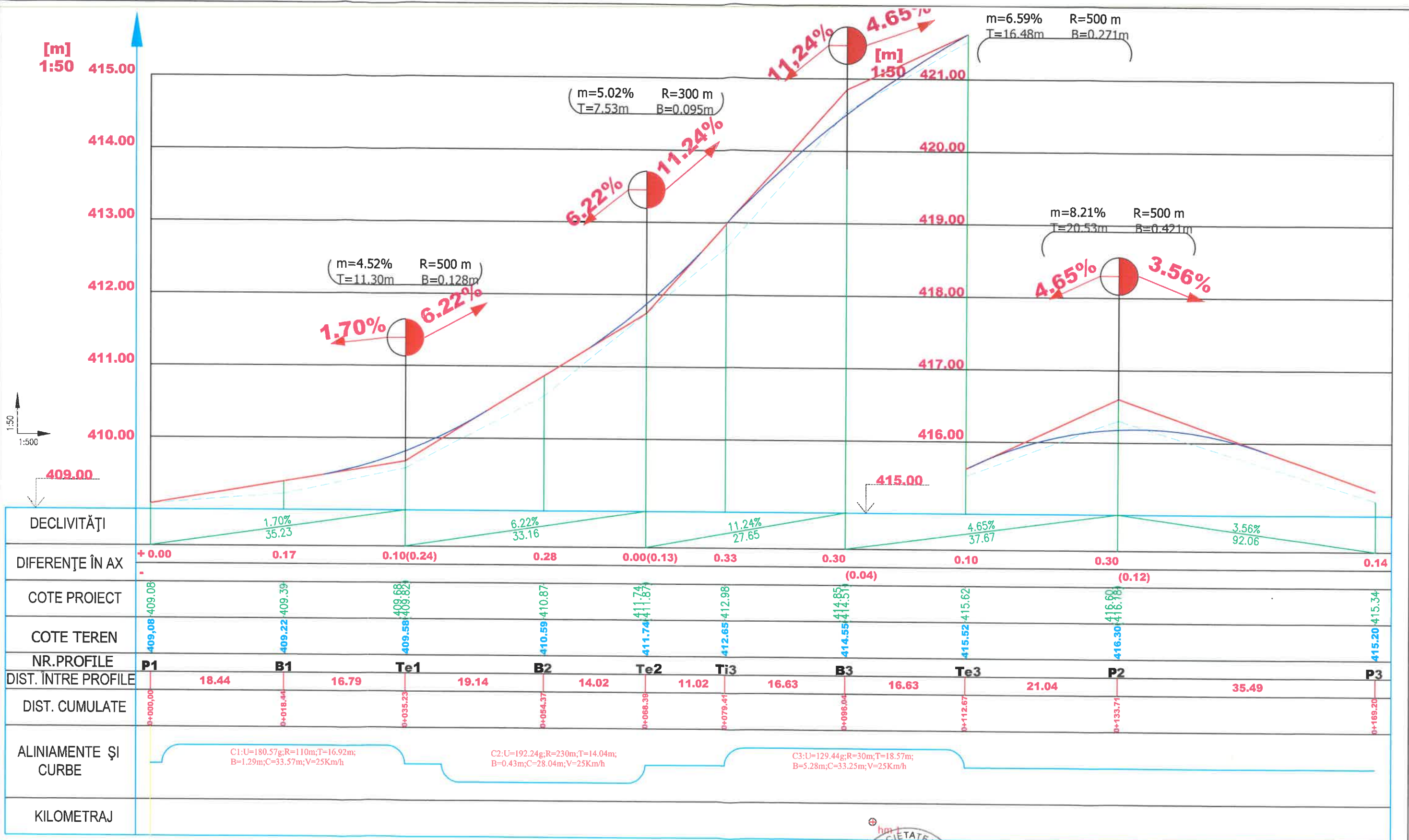

**Legenda**

- Linie teren proiectat
- Linie teren existent



S.C. NOVA PROIECT S.R.L.  
SUCEAVA  
CUI 3725693  
J33/1563/2007



BENEFICIAR: COMUNA HORODNIC DE JOS, JUDEȚUL SUCEAVA  
DENUMIRE PROIECT: "MODERNIZARE DRUM VICINAL DIN DC 46B LA HOTAR CU HORODNIC DE SUS IN COMUNA HORODNIC DE JOS, JUDEȚUL SUCEAVA"  
AMPLASAMENT: COMUNA HORODNIC DE JOS, JUDEȚUL SUCEAVA

	NUME	SEMNAȚURA	SCARA	DENUMIRE PLANȘA:	Nr. PROIECT
SEF PROIECT:	Ing. Cristea Claudiu		1:500	PROFIL LONGITUDINAL DRUM VICINAL KM 0+000,00-0+169,20	1/2020
PROIECTAT:	Ing. Tureatca Alexandru-Catalin		DATA		Faza:
DESENAT:	Ing. Onisoru Vlad		2020		P.T.+D.D.E
					Planșa:
					D.3.1.

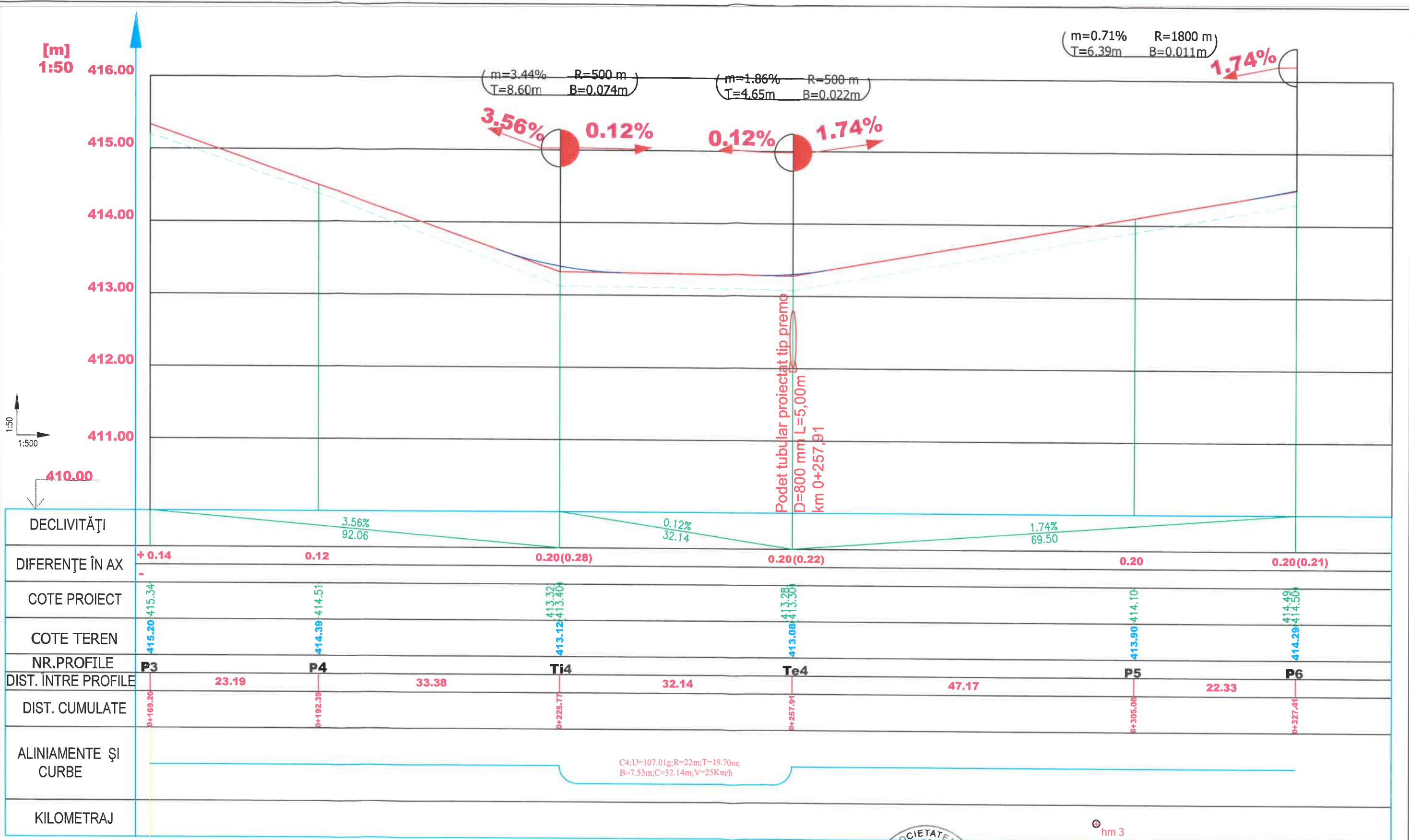

DECLIVITĂȚI	3.56% 92.06		0.12% 32.14		1.74% 69.50	
DIFERENȚE ÎN AX	+ 0.14	0.12	0.20(0.28)	0.20(0.22)	0.20	0.20(0.21)
COTE PROIECT	415.20	414.39	413.32	413.28	413.90	414.49
COTE TEREN	415.34	414.51	413.40	413.38	414.10	414.50
NR.PROFILE	P3	P4	Ti4	Te4	P5	P6
DIST. ÎNTRE PROFILE	23.19	33.38	32.14	47.17	22.33	
DIST. CUMULATE	0+169.20	0+192.39	0+225.77	0+257.91	0+305.08	0+327.41
ALINIAMENTE ȘI CURBE	C4: U=107.01g; R=22m; T=19.70m; B=7.53m; C=32.14m; V=25Km/h					
KILOMETRAJ	hm 3					

**Legenda**

- Linie teren proiectat
- - - Linie teren existent



S.C. NOVA PROJECT S.R.L.  
SUCEAVA  
J33/1563/2007



SEMNATURA



BENEFICIAR: COMUNA HORODNIC DE JOS, JUDEȚUL SUCEAVA  
DENUMIRE PROIECT: "MODERNIZARE DRUM VICINAL DIN DC 46B LA HOTAR CU HORODNIC DE SUS IN COMUNA HORODNIC DE JOS, JUDEȚUL SUCEAVA"  
AMPLASAMENT: COMUNA HORODNIC DE JOS, JUDEȚUL SUCEAVA

Nr. PROIECT  
1/2020

Faza:  
P.T.+D.D.E

SEF PROIECT:	ING. CRISTEA CLAUDIU	SCARA:	1:500 1:300
PROIECTAT:	ING. TUREATCA ALEXANDRU-CATALIN	DATA:	2020
DESESTAT:	ING. ONISORU VLAD		

DENUMIRE PLANSĂ:  
**PROFIL LONGITUDINAL  
DRUM VICINAL  
KM 0+169.20-0+327.41**

Plansa:  
D.3.2.

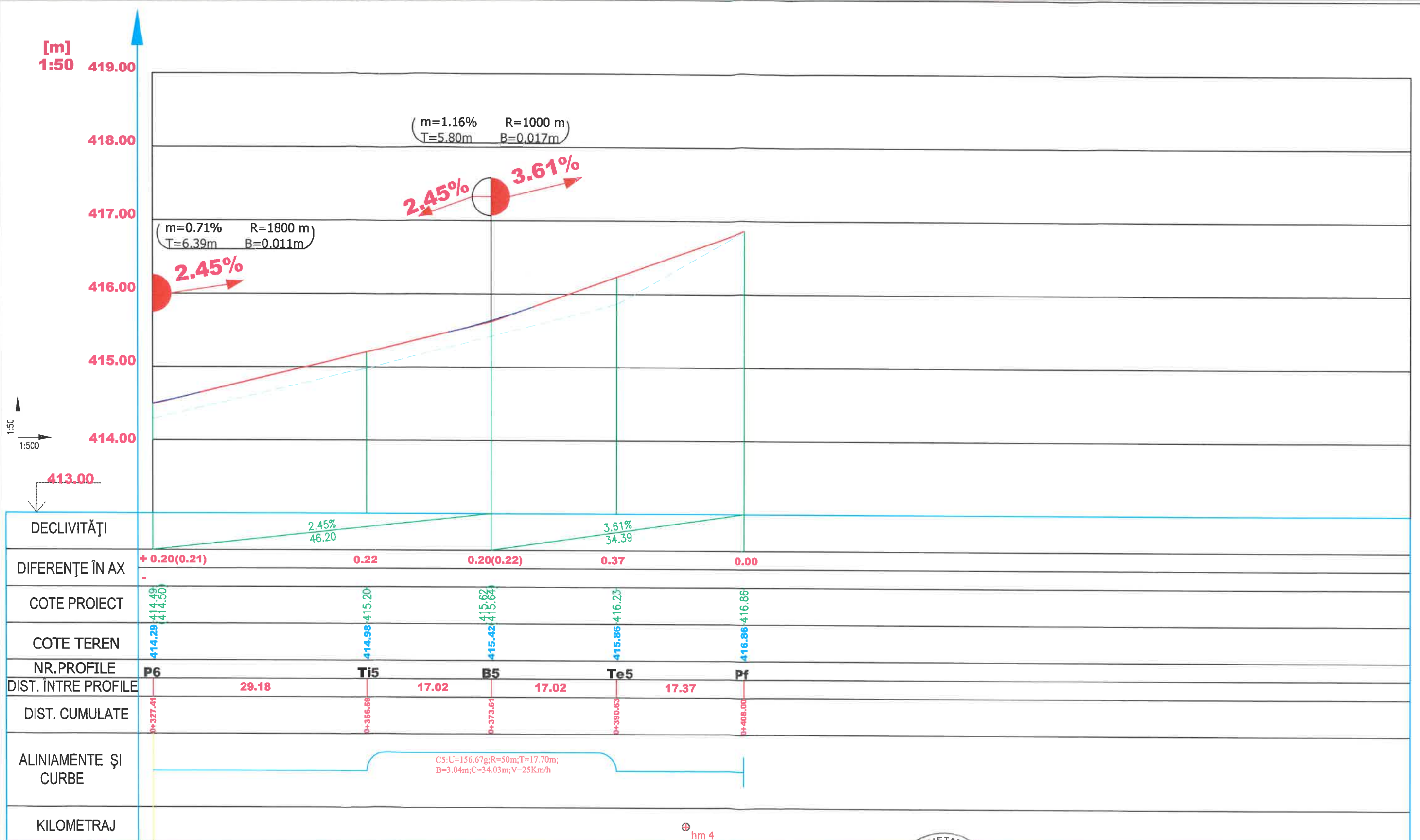

DECLIVITĂȚI		2.45%		3.61%	
		46.20		34.39	
DIFERENȚE ÎN AX		+ 0.20(0.21)	0.22	0.20(0.22)	0.37
					0.00
COTE PROIECT		414.49 414.50	415.20	415.62 415.64	416.23
COTE TEREN		414.29	414.98	415.42	415.86
NR.PROFILE		P6	T15	B5	Te5
DIST. ÎNTRE PROFILE			29.18	17.02	17.02
DIST. CUMULATE		0+327.41	0+356.59	0+373.61	0+390.63
					0+408.00
ALINIAMENTE ȘI CURBE			CS;U=156.67g;R=50m;T=17.70m; B=3.04m;C=34.03m;V=25Km/h		
KILOMETRAJ					hm 4

**Legenda**

— Linie teren proiectat

- - - Linie teren existent



S.C. NOVA PROIECT S.R.L.  
SUCEAVA  
J33/1563/2007



BENEFICIAR: COMUNA HORODNIC DE JOS, JUDEȚUL SUCEAVA

DENUMIRE PROIECT: "MODERNIZARE DRUM VICINAL DIN DC 46B LA HOTAR CU HORODNIC DE SUS IN COMUNA HORODNIC DE JOS, JUDEȚUL SUCEAVA"

AMPLASAMENT: COMUNA HORODNIC DE JOS, JUDEȚUL SUCEAVA

Nr.PROIECT 1/2020

Faza: P.T.+D.D.E

	NUME	SEMNTURA	SCARA	DENUMIRE PLANSĂ:
SEF PROIECT:	Ing. Cristea Claudiu		1:500 1:50	PROFIL LONGITUDINAL DRUM VICINAL KM 0+327.41-0+408.00
PROIECTAT:	Ing. Tureatca Alexandru-Catalin		DATA	
DEENAT:	Ing. Onisoru Vlad		2020	

Plansa: D.3.3.



PROFIL TRANSVESAL P1  
KM 0+000.00

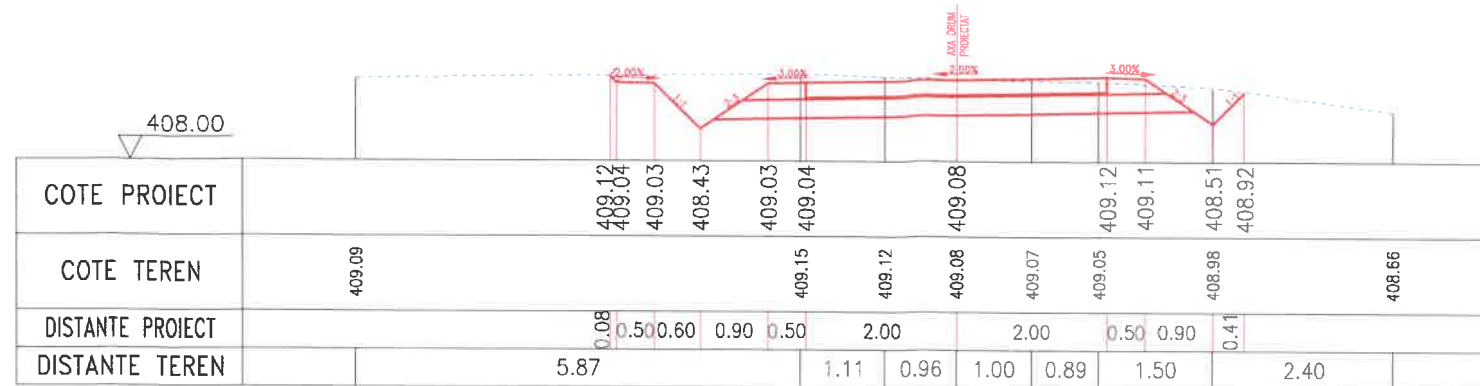

PROFIL TRANSVESAL B1  
KM 0+018,44

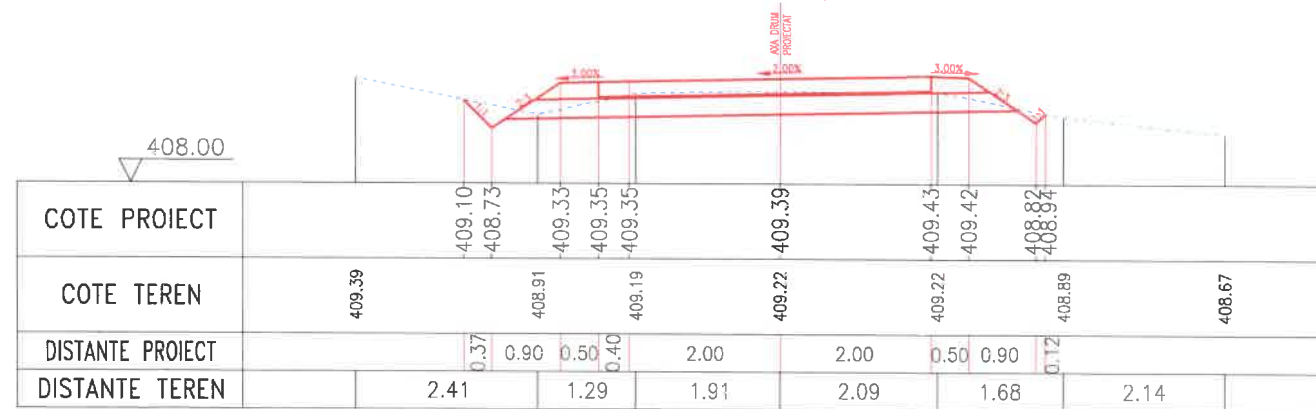

PROFIL TRANSVESAL B2  
KM 0+054.37

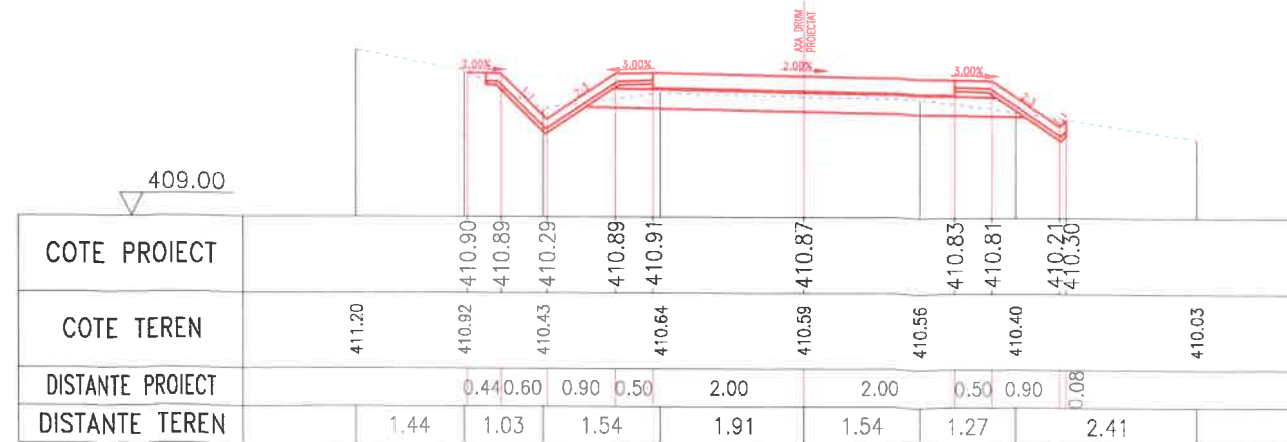

HARTA CHEIE:



PROIECTAT:

  
 SOCIETATEA S.C. NOVA PROIECT S.R.L.
   
 J33/1563/2007, CUI RO 22569792
   
 SUCEAVA, STR. BUIENII MARI NR. 5 BI. 52 Sc. A SECEAVA
   
 Telefon: 0740238021
   
 EMAIL: novaproiect1@gmail.com

VERIFICATOR:

NUME:	
SEMNTATURA	
CERINTA	
REFERAT NR./DATA	

BENEFICIAR:

COMUNA HORODNIC DE JOS  
JUDEȚUL SUCEAVA

DENUMIRE PROIECT:

„MODERNIZARE DRUM VICINAL DIN DC 46B LA HOTAR CU HORODNIC DE SUS, IN COMUNA HORODNIC DE JOS, JUDEȚUL SUCEAVA,

FAZA:

PROIECT TEHNIC  
+  
DETALII DE EXECUTIE

SEF PROIECT	SEMNTATURA
Ing. Claudiu Dumitru CRISTEA	
PROIECTAT	SEMNTATURA
Ing. Alexandru-Catalin TUREATCA	
DESENAT	SEMNTATURA
Ing. Vlad ONISORU	

DENUMIRE PLANSA:

PROFILE TRANSVERSALE  
CARACTERISTICE DRUM VICINAL

PLANSĂ NR.:	D 4.1.
SCARA:	1:100
PROIECT NR.:	1/2020
DATA:	2020

## HARTA CHEIE:



## PROIECTAT:

**NOVA PROIECT**  
 S.C. NOVA PROIECT S.R.L.  
 J33/1563/2007 CUI RO 2258097  
 SUCEAVA, STR. RULMENTULUI NR.5 BI.52 So. A09.4  
 Telefon: 0740238022 2569199  
 EMAIL: novaproiect1@gmail.com

## VERIFICATOR:

NUME: \_\_\_\_\_

SEMNATURA \_\_\_\_\_

CERINTA \_\_\_\_\_

REFERAT NR./DATA \_\_\_\_\_

## BENEFICIAR:

COMUNA HORODNIC DE JOS  
 JUDEȚUL SUCEAVA

## DENUMIRE PROIECT:

„MODERNIZARE DRUM VICINAL DIN DC 46B LA HOTAR CU HORODNIC DE SUS, IN COMUNA HORODNIC DE JOS, JUDEȚUL SUCEAVA,

## FAZA:

PROIECT TEHNIC  
 +  
 DETALII DE EXECUTIE

SEF PROIECT	SEMNATURA
Ing. Claudiu Dumitru CRISTEA	
PROIECTAT	SEMNATURA
Ing. Alexandru-Catalin TUREATCA	
DESENAT	SEMNATURA
Ing. Viad ONISORU	

## DENUMIRE PLANSA:

PROFILE TRANSVERSALE  
 CARACTERISTICE DRUM VICINAL

PLANSA NR.: D 4.2.

SCARA: 1:100

PROIECT NR.: 1/2020

DATA: 2020

### PROFIL TRANSVESAL Ti3 KM 0+079,41

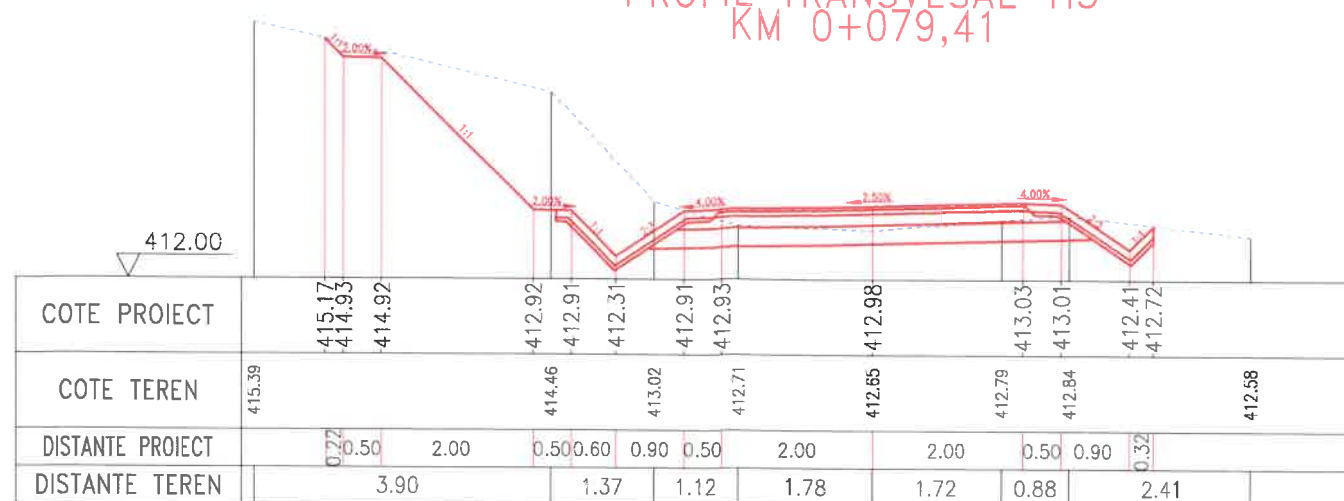

### PROFIL TRANSVESAL B3 KM 0+096,04

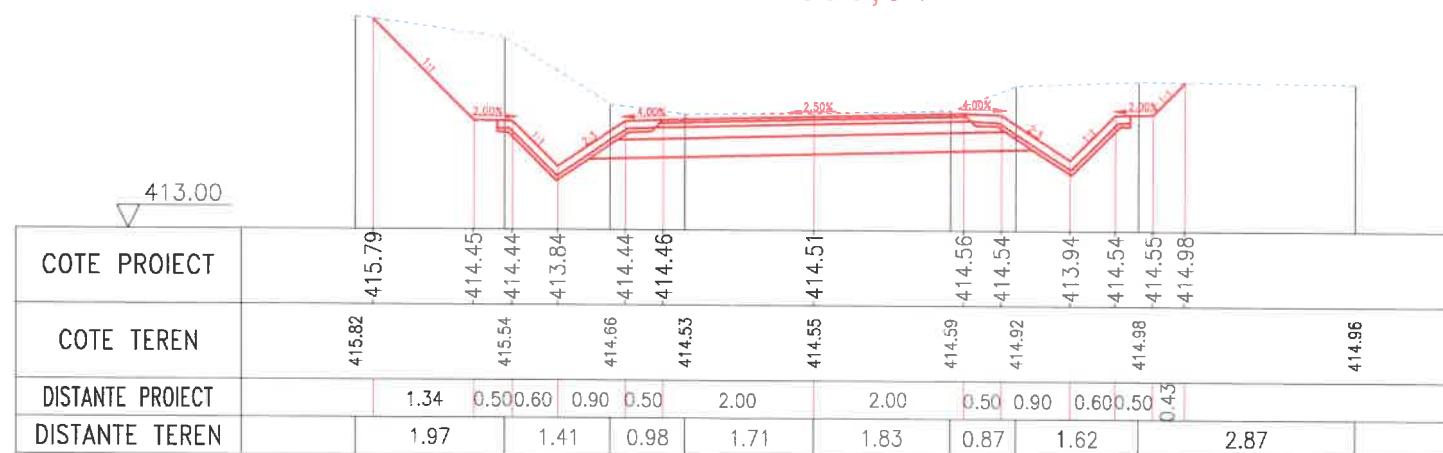

### PROFIL TRANSVESAL P2 KM 0+133,71

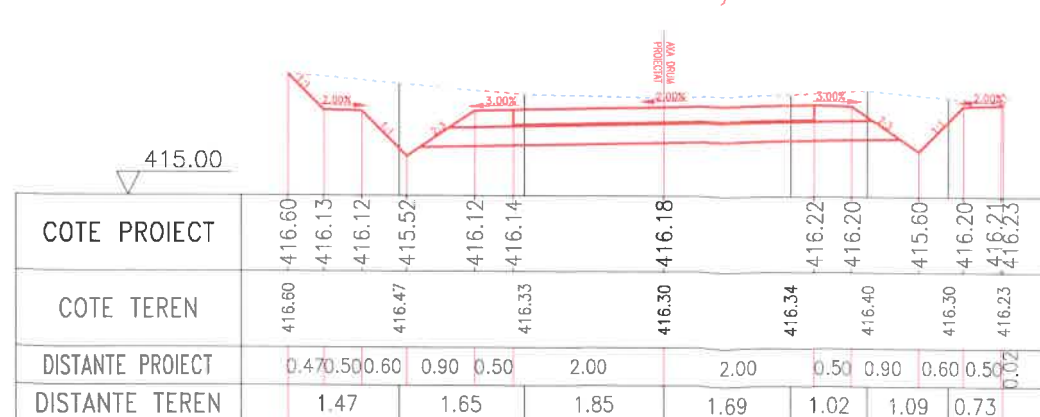

## HARTA CHEIE:



## PROIECTAT:

**NOVA PROIECT** S.C. NOVA  
 SUCHEA, S.R.L.  
 J33/1563/2007, CUI RO 22569792  
 SUCEAVA, STR. RULMENTULUI  
 NR.5 BI.52, Sc. A ap.4  
 Telefon: 0740298021  
 EMAIL: novaproiect@suceava.ro

## VERIFICATOR:

NUME:

SEMNATURA

CERINTA

REFERAT NR./DATA

## BENEFICIAR:

COMUNA HORODNIC DE JOS  
 JUDEȚUL SUCEAVA

## DENUMIRE PROIECT:

„MODERNIZARE DRUM  
 VICINAL DIN DC 46B LA  
 HOTAR CU HORODNIC DE  
 SUS, IN COMUNA  
 HORODNIC DE JOS,  
 JUDEȚUL SUCEAVA,

## FAZA:

PROIECT TEHNIC  
 +  
 DETALII DE EXECUTIE

SEF PROIECT SEMNATURA

Ing. Claudiu Dumitru  
 CRISTEA

PROIECTAT SEMNATURA

Ing. Alexandru-Catalin  
 TUREATCA

DESENAT SEMNATURA

Ing. Vlad ONISORU

## DENUMIRE PLANSA:

PROFILE TRANSVERSALE  
 CARACTERISTICE DRUM VICINAL

PLANSA NR.: D 4.3.

SCARA: 1:100

PROIECT NR.: 1/2020

DATA: 2020

### PROFIL TRANSVESAL P3 KM 0+169,20

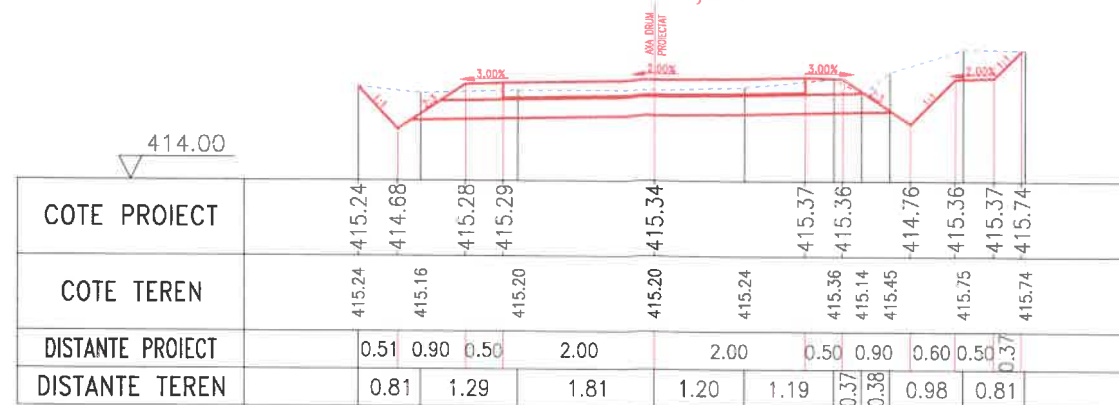

### PROFIL TRANSVESAL P4 KM 0+192,39

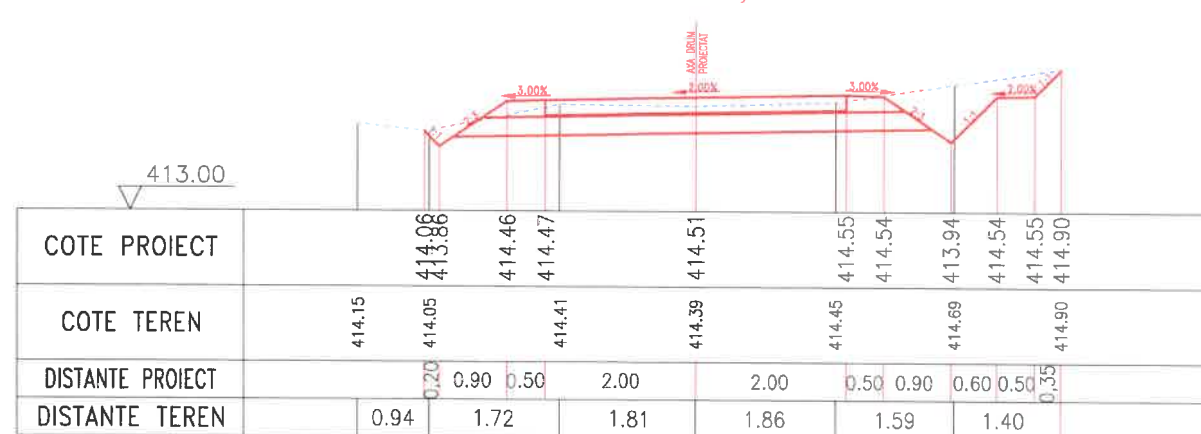

### PROFIL TRANSVESAL T14 KM 0+225,77

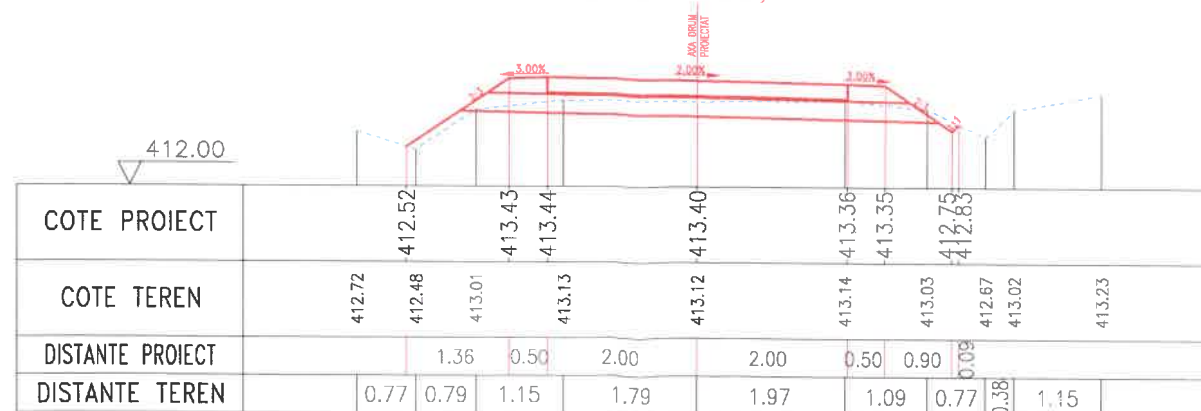

PROFIL TRANSVESAL Te4  
KM 0+257,91

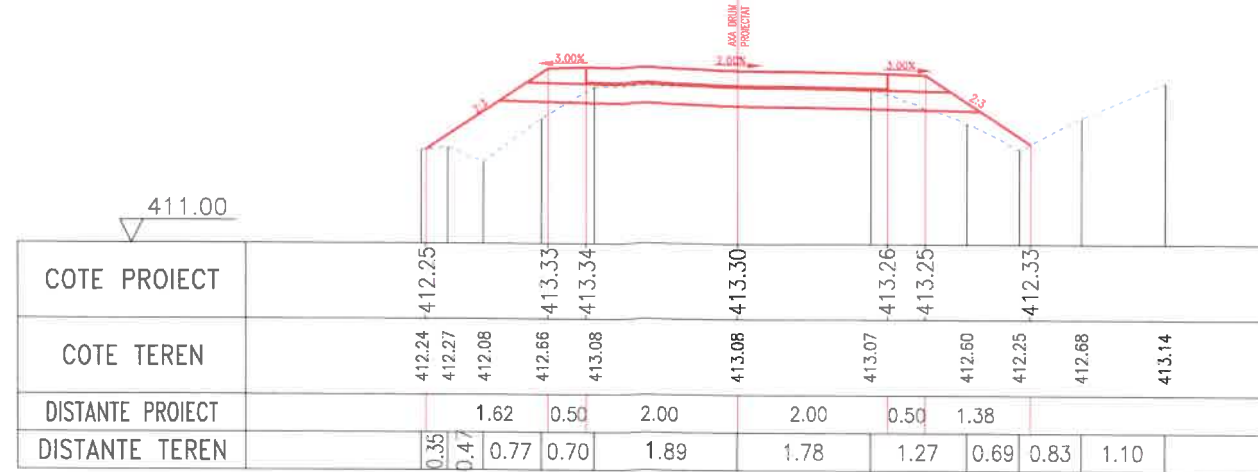

PROFIL TRANSVESAL P5  
KM 0+305,08

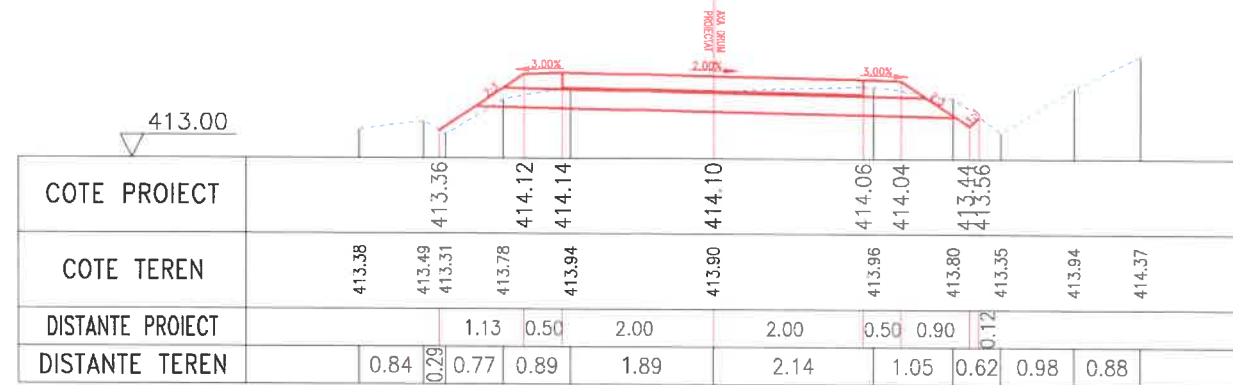

PROFIL TRANSVESAL P6  
KM 0+327,41

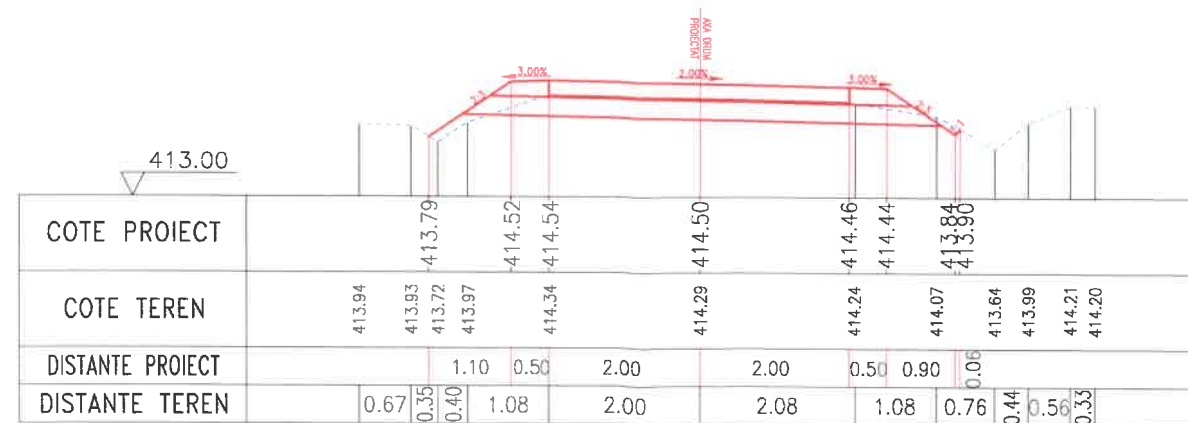

HARTA CHEIE:



PROIECTAT:

**NOVA PROIECT** S.C. NOVA SOCIETATE S.R.L.  
 J33/1563/2007, CUI RO 22569792  
 SUCEAVA, STR. ROLMENTULUI NR.5 Bl.52 Str.A ap.4 S.R.L.  
 Telefon:0740238021  
 EMAIL: novaproiect@univ.ro

VERIFICATOR:

NUME:

SEMNTURA

CERINTA

REFERAT NR./DATA

BENEFICIAR:

COMUNA HORODNIC DE JOS  
JUDETUL SUCEAVA

DENUMIRE PROIECT:

„MODERNIZARE DRUM VICINAL DIN DC 46B LA HOTAR CU HORODNIC DE SUS, IN COMUNA HORODNIC DE JOS, JUDETUL SUCEAVA,

FAZA:

PROIECT TEHNIC  
+  
DETALII DE EXECUTIE

SEF PROIECT SEMNTURA

Ing. Claudiu Dumitru CRISTEA

PROIECTAT SEMNTURA

Ing. Alexandru-Catalin TUREATCA

DESENAT SEMNTURA

Ing. Vlad ONISORU

DENUMIRE PLANSA:

PROFILE TRANSVERSALE CARACTERISTICE DRUM VICINAL

PLANSA NR.: D 4.4.

SCARA: 1:100

PROIECT NR.: 1/2020

DATA: 2020

## HARTA CHEIE:



## PROIECTAT:

**noVA** S.C. NOVA  
**PROIECT** S.R.L.  
 PROIECT NR. 1563/2007  
 J33/1563/2007, CUI RO 22569792  
 SUCEAVA, STR. NOVA PROIECT  
 NR. 5 BI. 52 Sc. A ap. 4 S.R.L.  
 Telefon: 0740238021  
 EMAIL: novaproiect1@gmail.com

## VERIFICATOR:

NUME:

SEMNTURA

CERINTA

REFERAT NR./DATA

## BENEFICIAR:

COMUNA HORODNIC DE JOS  
 JUDEȚUL SUCEAVA

## DENUMIRE PROIECT:

„MODERNIZARE DRUM  
 VICINAL DIN DC 46B LA  
 HOTAR CU HORODNIC DE  
 SUS, IN COMUNA  
 HORODNIC DE JOS,  
 JUDEȚUL SUCEAVA,

## FAZA:

PROIECT TEHNIC  
 +  
 DETALII DE EXECUTIE

SEF PROIECT SEMNTURA

Ing. Claudiu Dumitru  
 CRISTEA

PROIECTAT SEMNTURA

Ing. Alexandru-Catalin  
 TUREATCA

DESENAT SEMNTURA

Ing. Vlad ONISORU

## DENUMIRE PLANSA:

PROFILE TRANSVERSALE  
 CARACTERISTICE DRUM VICINAL

PLANSA NR.: D 4.5.

SCARA: 1:100

PROIECT NR.: 1/2020

DATA: 2020

### PROFIL TRANSVESAL Ti5 KM 0+356,59

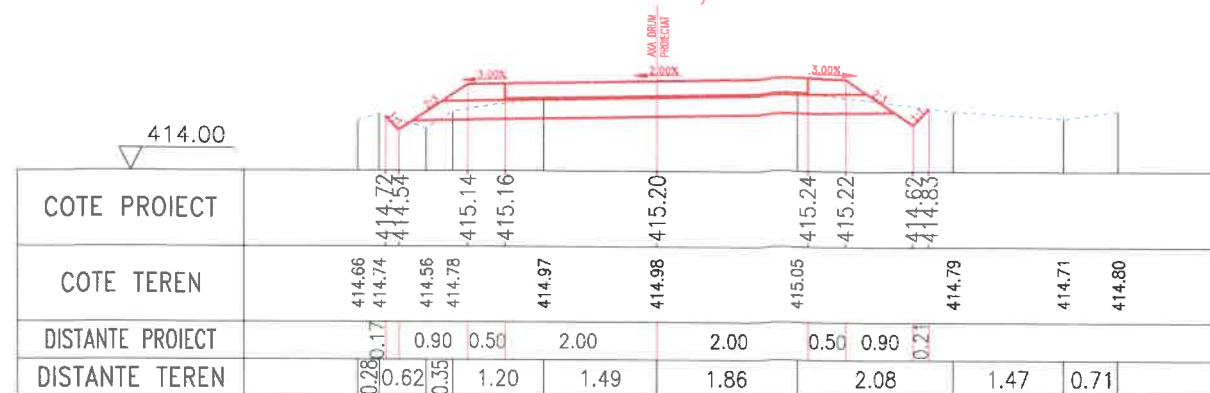

### PROFIL TRANSVESAL Te5 KM 0+390,63

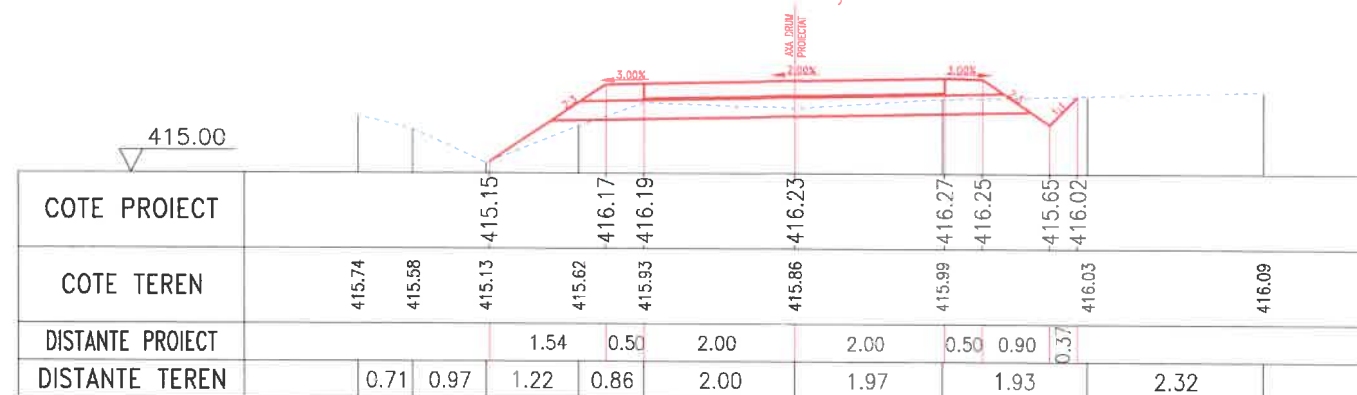

### PROFIL TRANSVESAL Pf KM 0+408,00

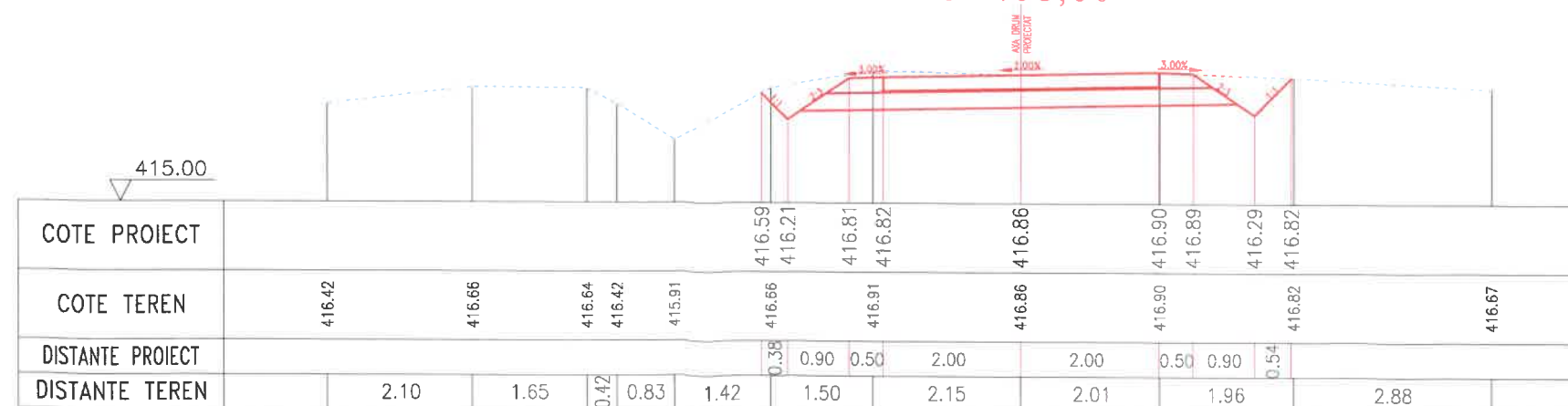

**DETALIU "A"-STRUCTURA RUTIERA**

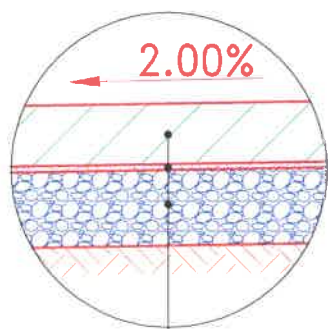

- Strat de uzura din BcR 4.0 - 20cm
- Hartie Kraft
- Strat de nisip - 2cm
- Strat de balast - 25cm

**PROFIL TRANSVERSAL TIP 1**

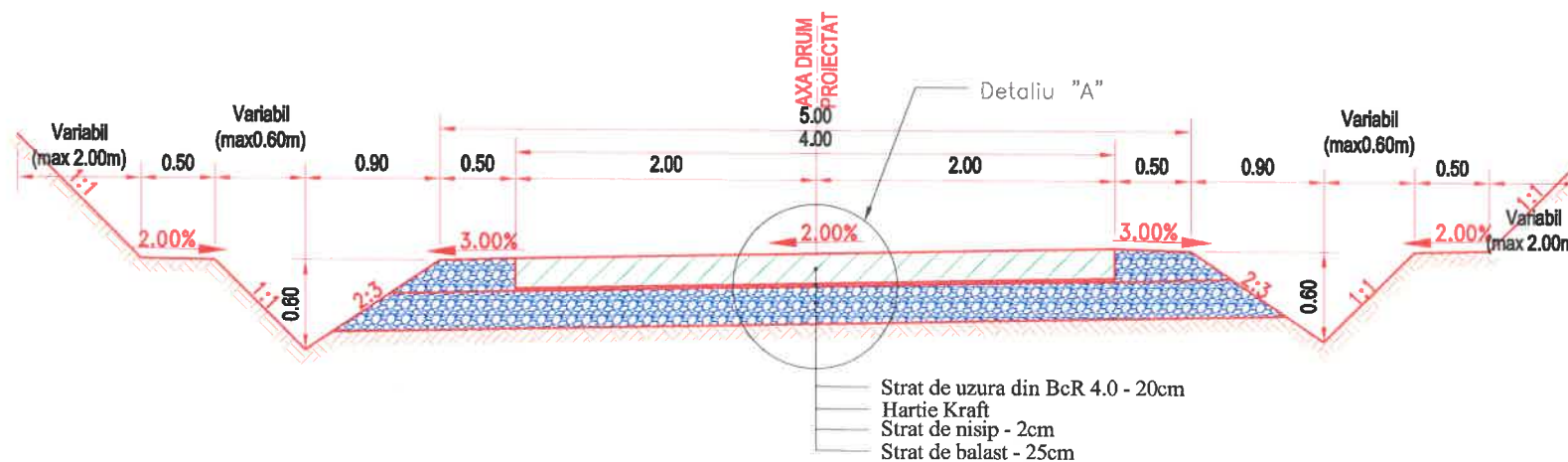

SE APLICA PE TRONSONUL:0+000.00-0+035.23  
 SE APLICA PE TRONSONUL:0+096.04-0+408.00

**NOTA:** Orice neconcordanța din proiect se va semnala imediat proiectantului de specialitate pentru soluționare. Modificarea distanțelor, grosimile straturilor fără acordul scris al proiectantului de specialitate îl absolvă pe acesta de orice responsabilitate.

**HARTA CHEIE:**



**PROIECTAT:**

**NOVA** PROIECT  
 S.C. NOVA PROIECT S.R.L.  
 J33/1563/2007/CI/EP/22569792  
 SUCEAVA, STR. RULMENTULUI NR.5 Bl.5 Sc. A ap.4  
 Telefon:0740278024  
 EMAIL: novaproiect@gmail.com

**VERIFICATOR:**

NUME:

SEMNTURA

CERINTA

REFERAT NR./DATA

**BENEFICIAR:**

**COMUNA HORODNIC DE JOS JUDEȚUL SUCEAVA**

**DENUMIRE PROIECT:**

**„MODERNIZARE DRUM VICINAL DIN DC 46B LA HOTAR CU HORODNIC DE SUS IN COMUNA HORODNIC DE JOS, JUDEȚUL SUCEAVA„**

**FAZA:**

PROIECT TEHNIC + DETALII DE EXECUTIE

SEF PROIECT	SEMNTURA
Ing. Claudiu Dumitru CRISTEA	
PROIECTAT	SEMNTURA
Ing. Alexandru-Catalin TUREATCA	
DESENAT	SEMNTURA
Ing. Viad ONISORU	

**DENUMIRE PLANSA:**

**PROFILE TRANSVERSALE TIP**

PLANSA NR.:	D 5.1.
SCARA:	1:50
PROIECT NR.:	1/2020
DATA:	2020

# DETALIU "A"-STRUCTURA RUTIERA

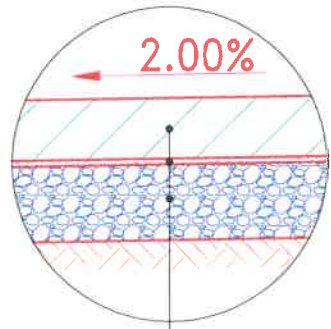

- Strat de uzura din BcR 4.0 - 20cm
- Hartie Kraft
- Strat de nisip - 2cm
- Strat de balast - 25cm

## PROFIL TRANSVERSAL TIP 2

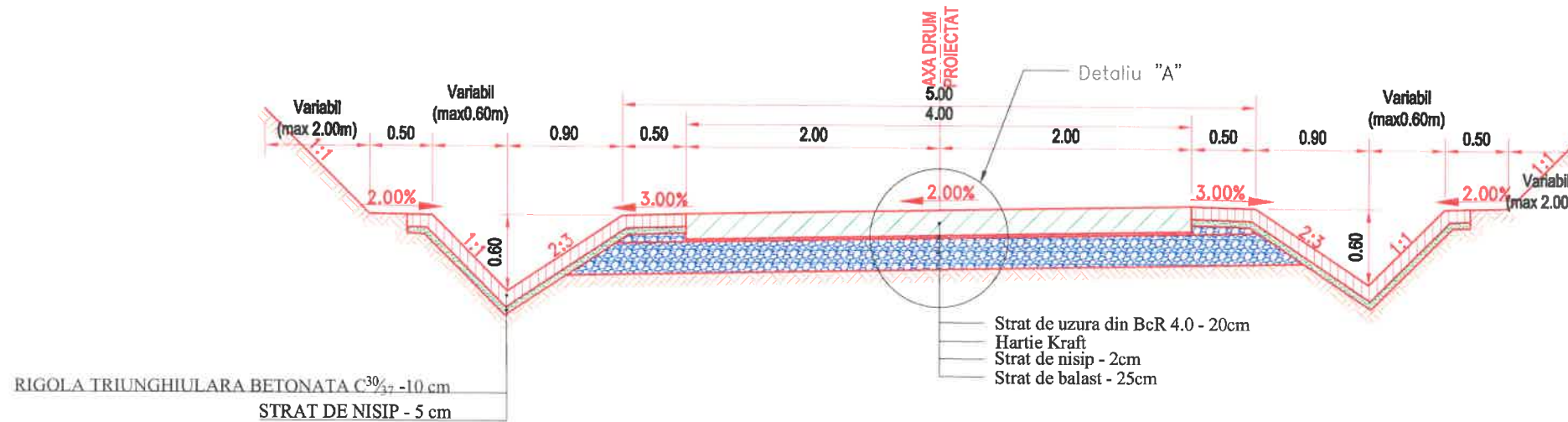

SE APLICA PE TRONSONUL: 0+035.23-0+068.39

### CERINTE DE DURABILITATE

- C30/37
- Clasa de expunere : XF1+XF4
- Impermeabilitate: P<sup>10</sup><sub>8</sub>
- Gelivitate: G100
- Ciment: CEM I 52.5R
- Valoare maxima A/C: 0.50
- Dozaj minim ciment 320 kg/m<sup>3</sup>
- Clasa de tasare S2
- Dimensiune maxima agregat 16mm

**NOTA:** Orice neconcordanta din proiect se va semnala imediat proiectantului de specialitate pentru solutionare. Modificarea distantelor, grosimile straturilor fara acordul scris al proiectantului de specialitate il absolve pe acesta de orice responsabilitate.

### HARTA CHEIE:



### PROIECTAT:

**noVA** PROIECT  
**SOCIETATEA** NOVA PROIECT S.R.L.  
 SUCEAVA, STR. ROMENTULUI NR.5 Bl.52 Sc. 2  
 Telefon: 0740238021  
 EMAIL: novaproiect1@gmail.com

### VERIFICATOR:

NUME:
SEMNTURA
CERINTA
REFERAT NR./DATA

### BENEFICIAR:

COMUNA HORODNIC DE JOS  
 JUDEUL SUCEAVA

### DENUMIRE PROIECT:

„MODERNIZARE DRUM VICINAL DIN DC 46B LA HOTAR CU HORODNIC DE SUS IN COMUNA HORODNIC DE JOS, JUDEUL SUCEAVA,

### FAZA:

PROIECT TEHNIC + DETALII DE EXECUTIE

SEF PROIECT	SEMNTURA
Ing. Claudiu Dumitru CRISTEA	<i>[Signature]</i>
PROIECTAT	SEMNTURA
Ing. Alexandru-Catalin TUREATCA	<i>[Signature]</i>
DESENAT	SEMNTURA
Ing. Vlad ONISORU	<i>[Signature]</i>

### DENUMIRE PLANSA:

PROFILE TRANSVERSALE TIP

PLANSA NR.:	D 5.2.
SCARA:	1:50
PROIECT NR.:	1/2020
DATA:	2020

DETALIU "A"-STRUCTURA RUTIERA

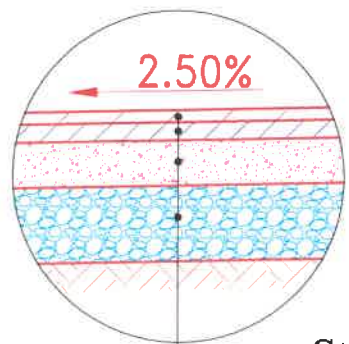

- Strat de uzura din MAS16 - 4cm
- Strat de legatura din BADPC22.4 - 6cm
- Strat de baza din piatra sparta - 15cm
- Strat de fundatie din balast - 25cm

PROFIL TRANSVERSAL TIP 3

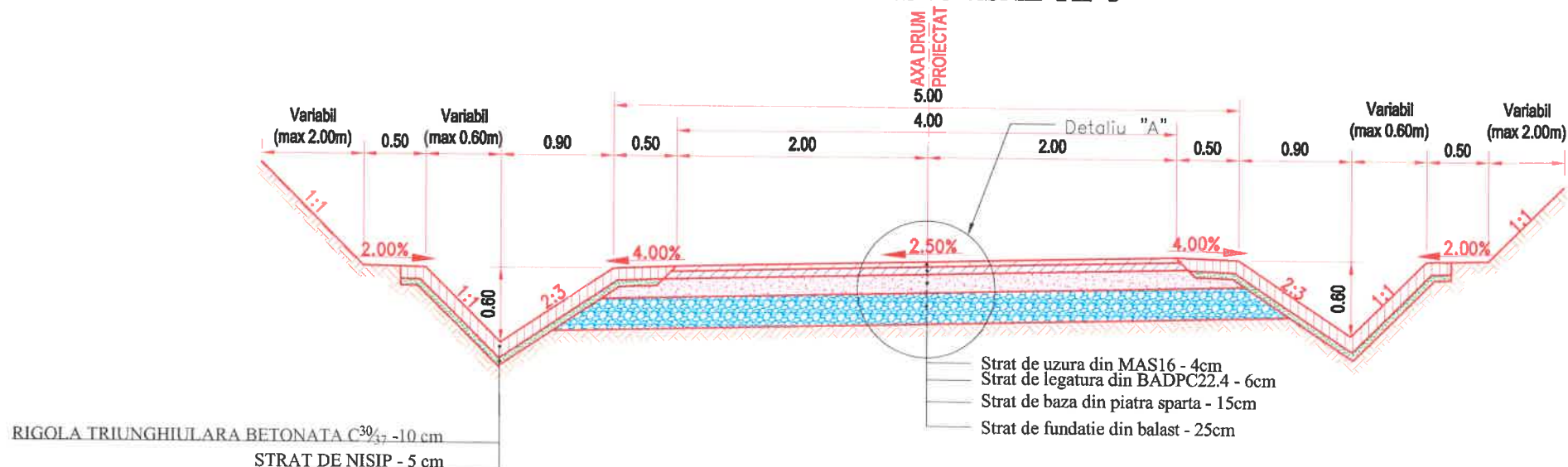

SE APLICA PE TRONSONUL:0+068.39-0+096.04

CERINTE DE DURABILITATE

- C30/37
- Clasa de expunere : XF1+XF4
- Impermeabilitate: P<sup>10</sup><sub>8</sub>
- Gelivitate: G100
- Ciment: CEM I 52.5R
- Valoare maxima A/C:0.50
- Dozaj minim ciment 320 kg/m<sup>3</sup>
- Clasa de tasare S2
- Dimensiune maxima agregat 16mm

NOTA: Orice neconcordanta din proiect se va semnala imediat proiectantului de specialitate pentru solutionare. Modificarea distantelor, grosimile straturilor fara acordul scris al proiectantului de specialitate il absolve pe acesta de orice responsabilitate.

HARTA CHEIE:



PROIECTAT:



J33/1563/2007, CUI RO 22568792  
 SUCEAVA, STR. CULMENIULUI NR.5 BI.52 SUCEAVA  
 Telefon:0740238021  
 EMAIL: novaproiect1@gmail.com

VERIFICATOR:

NUME:

SEMNTURA

CERINTA

REFERAT NR./DATA

BENEFICIAR:

COMUNA HORODNIC DE JOS  
 JUDEȚUL SUCEAVA

DENUMIRE PROIECT:

„MODERNIZARE DRUM VICINAL DIN DC 46B LA HOTAR CU HORODNIC DE SUS IN COMUNA HORODNIC DE JOS, JUDEȚUL SUCEAVA,

FAZA:

PROIECT TEHNIC + DETALII DE EXECUTIE

SEF PROIECT	SEMNTURA
Ing. Claudiu Dumitru CRISTEA	
PROIECTAT	SEMNTURA
Ing. Alexandru-Catalin TUREATCA	
DESENAT	SEMNTURA
Ing. Vlad ONISORU	

DENUMIRE PLANSA:

PROFILE TRANSVERSALE TIP

PLANSA NR.: D 5.3.

SCARA: 1:50

PROIECT NR.: 1/2020

DATA: 2020



